



MCAC706

Ports details

X1: control signal input / output

Terminal block	Sign	Name	Note
1	DIR+	Positive direction input	High effective
2	DIR-	Negative direction input	Low effective
3	PUL+	Pulse positive input	High effective
4	PUL-	Pulse negative input	Low effective
5	ERC+	Positive servo reset input	High effective
6	ERC-	Negative servo reset input	Low effective

X2: feedback signal input of encoder

Terminal block	Sign	Name	Note
1	GND	Output power ground	
2	VCC	Output power	50mA
3	PW+	Positive input of field pole W phase	Single end connection
4	PV+	Positive input of field pole V phase	Single end connection
5	PU+	Positive input of field pole U phase	Single end connection
6	PZ+	Positive input of encoder Z phase	
7	PB+	Positive input of encoder B phase	
8	PA+	Positive input of encoder A phase	
9	NC		
10	NC		
11	NC		
12	NC		

13	PZ-	Negative input of encoder Z phase	
14	PB-	Negative input of encoder B phase	
15	PA-	Negative input of encoder A phase	

X3: power

Terminal block	Identifier	Sign	Name
1	Electric engine phase wire	W	Motor terminal W
2		V	Motor terminal V
3		U	Motor terminal U
4	Input power	VDC	Input DC power supply
5		GND	Input power ground

Analog value input and communication interface

Outlet	Signal definition
2	RX
3	GND
5	TX
6	VCC

Installation dimension

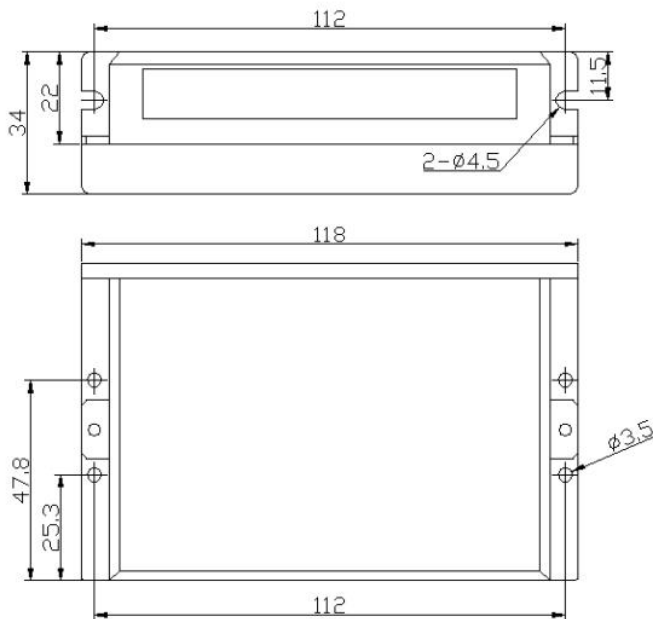

wiring diagram

The typical wiring diagram of the servo system is as follows:

This drive can provide +5V to the encoder and maximum 80mA power supply. Counting by four times frequency. Encoder resolution 4 times is the number of pulses per revolution of the servo motor.

